

karma

User manual

Ergo Recline Series

(KM-5001)



A Better Wheelchair, A Better Fit

Contents



1. Preface	1
1.1 General warnings	1
1.2 You and your KARMA service provider	3
1.3 CE marking	4
2. Safety	5
2.1 Doorways	5
2.2 Leaning	5
2.3 Negotiating inclines	5
2.4 Kerbs (curbs)	6
2.5 Stairs	6
2.6 Streets	7
2.7 General	7
2.8 Upholstery	7
2.9 Anti-tippers	8
2.10 Maximum user weight limit	9
2.11 Avoid general misuse	9
2.12 Labeling	10
3. Intended use and parts	11
3.1 Intended use	11
3.2 Parts description	12
3.3 Wheel locks	12
4. Operation	13
4.1 Preparing for use	13
4.2 Making adjustments	16
4.3 Transferring in and out	21
4.4 General use	23
4.5 Storing	27
4.6 Transportation	27
4.7 Pelvic belt	30
5. Inspection and maintenance	32
5.1 Daily check	32

5.2 Regular maintenance record	32
6. Options and accessories.....	34
7. Troubleshooting	35
7.1 Common issues and troubleshooting tips	35
8. Specifications	36
9. Cleaning and recycling	38
9.1 Cleaning	38
9.2 Post-consumer recycling	38
10. Warranty	39
10.1 Serial number	39
10.2 Warranty policy	39

1. Preface

Please carefully read this manual before using the wheelchair. Improper use of the wheelchair could result in harm or injury. Therefore, for safe and enjoyable use of the wheelchair, please read this manual.

- This manual includes operation instructions for many aspects of the wheelchair, unfolding/folding instructions and instructions on how to deal with possible accidents.
- This manual is written for KARMA wheelchair: Ergo Recline series.
- The symbols used in this manual are explained below. Pay special attention to the parts marked with these symbols.

 WARNING	Improper use could lead the user to severe injury or death.
 CAUTION	Improper use could lead the user to severe injury and/or damage to your wheelchair.
 NOTE	Follow these instructions to keep the wheelchair in good condition.

- This manual includes the repair and maintenance chart as well as the warranty.
- If someone else uses the wheelchair, make sure that you give him or her this manual for his or her reference.
- As designs change, some illustrations and pictures in this manual may not correspond to the wheelchair that you purchased. We reserve the right to make design modifications without further notice.

1.1 General warnings

- DO maintain your wheelchair well. In particular, check the tyre (tire) pressure since this affects the efficiency of the brakes. For the correct tyre (tire) pressure, please see the walls of the tyres (tires).
- DO make sure both wheel locks are applied before getting into or out of the wheelchair.
- DO make sure both wheel locks are applied when the wheelchair is not being pushed or used.
- DO take care when climbing kerbs (curbs) or turning on slopes.
- DO travel smoothly in all conditions.
- DO look well ahead to anticipate hazards, such as furniture, doors, potholes, etc.
- DO make sure that both feet are safely on the legrests and that clothing is safely tucked out of the way so that it cannot get caught in the wheels.
- DO take care when traveling up or down or across inclines.
- DO keep both hands on the rigidifying push bar (lateral support bar) to control

the wheelchair, if you are the attendant.

- DO pay attention to keep the wheelchair balanced.
- DO check the frame and components regularly and refer to this manual during and after the warranty period.
- DO tie up the upholstery or replace it with a new one when it becomes loose.
- DO lubricate bearings regularly.
- DO equip with anti-tippers to avoid falling backwards.
- DO equip with a pelvic belt designed for disabled people.
- DO clean both hands after oiling the wheelchair.
- DO keep far away from flame.
- DO avoid steep or uneven surfaces that may cause the wheelchair to tip over.
- DO avoid soft surfaces as the front casters may become bogged down.
- DO avoid directional changes on slopes/ramps.
- DO NOT make a U-turn on slopes/ramps.
- DO NOT overload the wheelchair in any circumstances.
- DO NOT hang anything heavy on the back of the wheelchair that could cause the wheelchair to become unstable, particularly when negotiating inclines.
- DO NOT allow more than one user at a time.
- DO NOT use with an unconscious patient.
- DO NOT use other transport to pull the wheelchair.
- DO NOT do "wheelies", since you might fall or tip over backwards and suffer a severe injury.
- DO NOT sit in the wheelchair within a moving vehicle unless it has been affixed the labels of a hook mark. The labels of a hook mark mean that the wheelchair fulfils the performance requirements for a "Crash Test" of ISO 7176-19 and is suitable to use as a seat in vehicles that have been adapted for this purpose.
- DO NOT go too fast or turn too quickly.
- DO NOT stand on the footplates when getting into or out of the wheelchair. Otherwise, the wheelchair will tip forwards.
- DO NOT go down steps forward, whether solo or with an attendant.
- DO NOT attempt to lift the wheelchair by any removable (detachable) parts. Lifting by means of any removable (detachable) parts of the wheelchair may result in injury to the user and/or assistant/attendant or damage to the wheelchair.

- DO NOT use the wheelchair when the backrest is folded. This alters the center of gravity and may cause the wheelchair to tip backwards. The backrest should only be folded for storage or transport of the wheelchair.

1.2 You and your KARMA service provider

- No tools are required for assembly. Your wheelchair should be assembled by your authorized KARMA dealer. Your authorized KARMA dealer is also your service provider. Unauthorized repairs, upgrades and add-ons will void your warranty. Anything wheelchair related that requires tools should be done by your authorized KARMA service provider. Your KARMA service provider has the necessary service/maintenance manual for your wheelchair.
- If you have any defective parts or lose any parts, please contact your dealer for repair and/or replacement. Please only use parts authorized by KARMA. Use of parts that are not authorized by KARMA will void your warranty.
- Part numbers are listed on our bill of materials (explosion drawings), which we give to our authorized dealers and service providers. Customers should order parts through their dealer as well as all repairs and scheduled maintenance.
- Customers should go to their dealership for all service needs to guarantee their warranty is not void. Always go to an authorized service provider. Unauthorized repairs will void your warranty. Procedures other than those described in this manual must be performed by a qualified technician. They also have the service manual with a complete list of maintenance required to keep your KARMA wheelchair in top performance. Check the "Warranty" chapter of this manual to find out what KARMA guarantees and what maintenance service and parts that are not covered by the warranty.
- KARMA does not have an official list of service providers at this time. Please contact your dealer for service. If you cannot contact your dealer, please contact another authorized KARMA dealer for service. If all else fails, contact KARMA directly via our website or give us a call, and we can refer you to your new service provider.

1.3 CE marking

This wheelchair complies with the requirements of the Medical Devices Regulation (EU) 2017/745.



CAUTION

- When prescribing wheelchairs for use by full or partial amputees (above or below knees, single or double) or other conditions that affect the user's natural center of gravity and might cause the wheelchair to tip or the person on the wheelchair to fall off, we suggest contacting your therapist or dealer as well as attaching anti-tippers, a pelvic belt, or other additional safety accessories.
- When using the wheelchair, ALWAYS follow the Highway Code or your local traffic regulations when outdoors and the guidelines written in this manual.

2. Safety

2.1 Doorways

The safest way to operate the wheelchair is on level floors that are free of obstacles. Whenever possible, use a ramp to enter or exit a facility. Keeping your hands on the handrims will allow you to maintain maximum balance. Do not try to force yourself over an obstruction by propulsion and never use the sides of a doorway to pull yourself through a passageway.

2.2 Leaning



CAUTION

- Do not lean over either side of your wheelchair, since such an action may cause you to lose balance and fall. (See Figure 2.1.)
- When sitting on the wheelchair, do not attempt to pick up objects by leaning forward. (See Figure 2.2.)



Figure 2.1



Figure 2.2

2.3 Negotiating inclines

- Never turn on a hill due to the danger of tipping.
- When assisting, go straight up a slope. If the user needs to go down midway, walk backwards until the user is on level ground. (See Figure 2.3 and 2.4.)



Figure 2.3



Figure 2.4

- To avoid danger, do not drive over 7 degrees of incline. When negotiating inclines, don't propel over 3 degrees of incline diagonally.
- Avoid stopping on an incline, it can potentially cause you to lose control of the wheelchair.
- Do not use the wheel locks to slow down or stop the wheelchair. This could cause it to seize up, causing you to lose control or fall out of the wheelchair.
- Whenever possible, utilize help from an assistant/attendant while negotiating inclines.



CAUTION

Although the product has met ISO 7176-1 requirements, we still recommend you not to cross a slope (in any direction) greater than 7 degrees. If you have to cross slopes in your daily activities, we suggest you purchase and install anti-tippers to increase the stability of the wheelchair.

2.4 Kerbs (curbs)

- Whenever possible, utilize help from an assistant/attendant. If you have assistance, make sure that your wheelchair is equipped with the rigidifying push bar (lateral support bar).
- Avoid hard impacts when descending a kerb (curb). A hard impact could adversely affect the wheelchair.
- Never try to scale or descend kerbs (curbs) that exceed a normal height.
- Always take care when climbing kerbs (curbs) or turning on slopes and never move in reverse without an assistant/attendant.

2.5 Stairs

- Always use two or more assistants. Tilt the wheelchair to its point of equilibrium. One assistant (at the back) holds the wheelchair up against the first step, gripping the handles firmly to lift. The second assistant, holding firmly a fixed part of the front frame, lifts the wheelchair above the stairs and holds it while the first attendant places one foot on the following step and repeat the operation.



- Never go down steps forwards, whether solo or with an attendant.
- Never use an escalator for transport. Use an elevator instead.

2.6 Streets

- Always use extreme caution when crossing streets. Reflective tapes on the wheelchair and/or your clothing will make you more visible to drivers.
- Please comply with traffic safety code.
- Avoid potholes and rough terrain that might cause the front casters to become stuck.



2.7 General

- The expected service life of the product is **5 years**, presuming that the product is used daily in accordance with the safety operation instructions, inspection and maintenance instructions, and intended use that are described in this manual.
- Always make sure BOTH wheel locks are applied before getting into or out of the wheelchair.
- Never stand on the footplates when getting into or out of the wheelchair.
- Never carry more than one passenger. KARMA wheelchairs are limited to one user.
- Use caution to assure your clothing doesn't get tangled with the wheels.
- When the user is operating the wheelchair using the handrim, please push the wheelchair gently. DO NOT apply a sudden huge force on the handrim. It could cause the wheelchair to tip over. Please refer to the figure below for the best grip points for using the handrim.

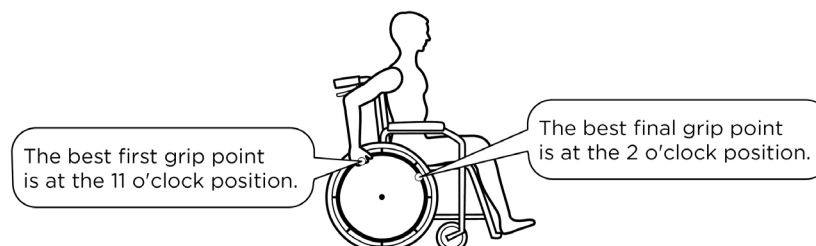

(Only for the Ergo Recline series with 20" rear wheels)

2.8 Upholstery

- When cleaning the upholstery, use warm water and a mild soap.
- Upholstery cleaner/foam can also be used, but avoid other cleaning solvents.
- Avoid frequent cleaning because this will affect its fire retardant performance.
- Stay away from flames, which might injure users and damage the wheelchair.

2.9 Anti-tippers

Anti-tippers prevent the wheelchair from tipping backwards. When you install the anti-tippers, if the anti-tippers are adjustable, please make sure:

- The distance between the end of each anti-tipper and the rear wheel is at least 50 mm.
- The distance to the floor does not exceed 50 mm.

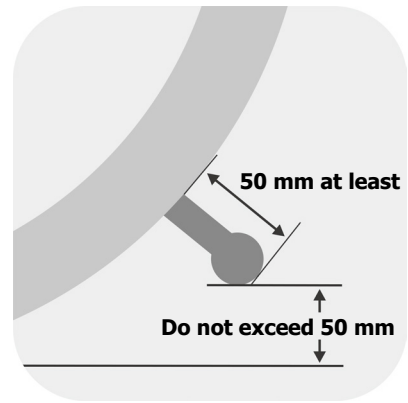

WARNING

- Please always check that the anti-tippers are working before using the wheelchair. Anti-tippers that are incorrectly set or damaged can lead to tipping over. Please turn to a KARMA authorized dealer when anti-tippers need to be installed or re-adjusted.
- The activated anti-tippers may bump into the ground when negotiating steps or kerbs (curbs). Therefore, deactivate the anti-tippers if needed.

To mount the anti-tippers, press the release buttons, and then insert them into the back of the side frame. Ensure the release buttons pop out properly in the fixing hole (A).

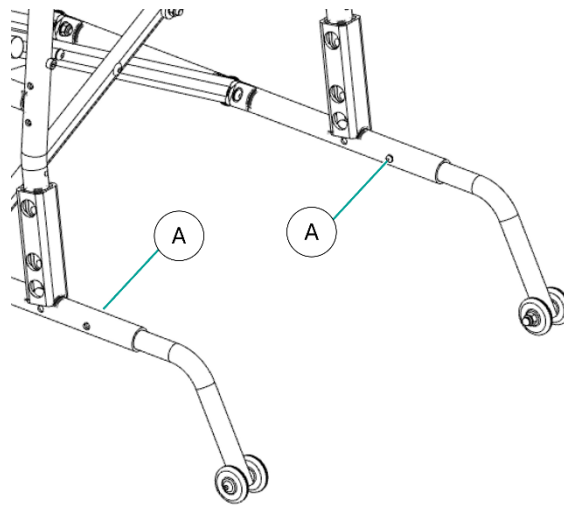

To turn the anti-tippers into the inactive position, rotate the anti-tippers by pressing the release buttons (A) and turning them up. Ensure the release buttons pop out again into place (B).

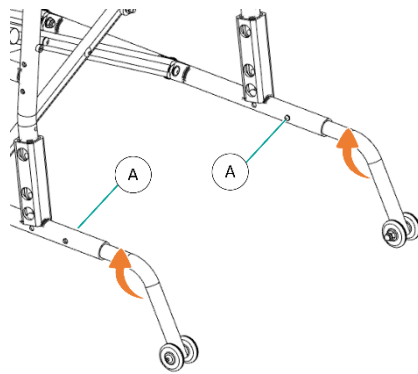

Active position

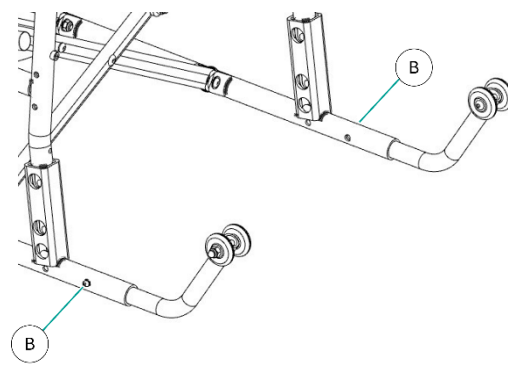

Inactive position

2.10 Maximum user weight limit

Refer to “Maximum User Weight” in [Chapter 8. Specifications](#). Loads exceeding maximum capacity can damage your wheelchair and cause malfunctions yielding a safety hazard. The warranty does not cover damage caused by improper operation of the wheelchair.

2.11 Avoid general misuse

Please note that our User Manual contains a number of cautions -- any vehicle can cause injury if misused -- use within our guidelines and with reasonable care and your safety will be increased. Your wheelchair will give years of safe use if used sensibly and carefully. Be aware that careless use endangers your own safety as well as that of others. ALWAYS follow the Highway Code when you are outdoors and the guidelines written in this manual.



CAUTION

- DO NOT stand or let children play on the wheelchair. (See Figure 2.5.)
- DO NOT hang any items other than an IV bag on the IV Pole Holder. (See Figure 2.6.)



Figure 2.5



Figure 2.6

2.12 Labeling

Please carefully read all the labeling on the wheelchair before driving it. Do not remove them. Protect them for future reference.



1

Model:	
Seat Width	Seat Depth
<input type="checkbox"/> 13	<input type="checkbox"/> 13
<input type="checkbox"/> 14	<input type="checkbox"/> 14
<input type="checkbox"/> 15	<input type="checkbox"/> 15
<input type="checkbox"/> 16	<input type="checkbox"/> 16
<input type="checkbox"/> 17 <input type="checkbox"/> 0	<input type="checkbox"/> 17 <input type="checkbox"/> 0
<input type="checkbox"/> 18 <input type="checkbox"/> 5	<input type="checkbox"/> 18 <input type="checkbox"/> 5
<input type="checkbox"/> 19	<input type="checkbox"/> 19
<input type="checkbox"/> 20	<input type="checkbox"/> 20
<input type="checkbox"/> 21	<input type="checkbox"/> 21
<input type="checkbox"/> 22	<input type="checkbox"/> 21
<input type="checkbox"/> _____	<input type="checkbox"/> _____

karma Unit: inch



3. Intended use and parts

3.1 Intended use

- The Ergo Recline series with 20" rear wheels is a self-propelled wheelchair, which can either be pushed by an attendant or by the user.
- The Ergo Recline series with 14" rear wheels is a transit wheelchair, which can be pushed by an attendant only.
- The Ergo Recline series is suitable for users up to 115 kg in weight. Please refer to the labeling on the wheelchair or "[8. Specifications](#)" for details.
- The Ergo Recline series has an extremely durable aluminum alloy frame with tough accessories and does not suffer in dramatic extremes of temperature (neither the user nor attendant need to touch metal parts in normal use).
- This wheelchair is designed for both indoor and outdoor use.
- The rear wheels have PU tyres (tires) for greater durability.

3.2 Parts description



- | | |
|--------------------------------------|--|
| 1. 3D headrest pillow | 11. Armrest flip back lever |
| 2. Backrest upholstery | 12. Wheel lock lever |
| 3. Pelvic belt | 13. Rear wheel |
| 4. Ship-shape armpad | 14. Anti-tipper |
| 5. Patented multi-functional armrest | 15. Front caster fork |
| 6. Elevating legrest | 16. Front caster |
| 7. Calf pad | 17. Rigidifying push bar (Lateral support bar) |
| 8. Footplate | 18. Reclining lever (Black) |
| 9. Armrest height adjustment lever | 19. Attendant brake (Red) |
| 10. Side guard | |

3.3 Wheel locks

The wheel locks can lock the wheels when stationary to prevent it from moving.

- To engage the wheel locks, push the wheel lock levers forwards as far as possible.
- To release the wheel locks, pull the wheel lock levers backwards.

4. Operation

4.1 Preparing for use

4.1.1 Unfolding

To unfold your wheelchair, follow the steps below:

1. Hold the armrests and pull outwards. (See Figure 4.1.)
2. Point your fingers inwards with the palm of your hand on the frame, and push it down until the seat is fully lowered. Make sure the frame is firmly seated in its holder. (See Figure 4.2.)



CAUTION

When completing the step above, never put your fingers around the sides or under the wheelchair, as they can be trapped between the seat and the frame. (See Figure 4.3.)

3. Attach the elevating legrest onto the wheelchair. Rotate inwards and make sure the legrest clicks into place. (See Figure 4.4.)
4. Swivel the footplates inward down. (See Figure 4.5.)
5. Push the rigidifying push bar (lateral support bar) upwards, and then tighten the knob at the center. (See Figure 4.6.)
6. Install the headrest frame and attach the 3D headrest pillow. (Refer to “[4.1.3 Installing or removing the headrest](#)” for details.)
7. Ready to use!

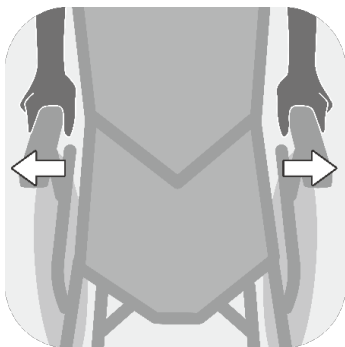

Figure 4.1

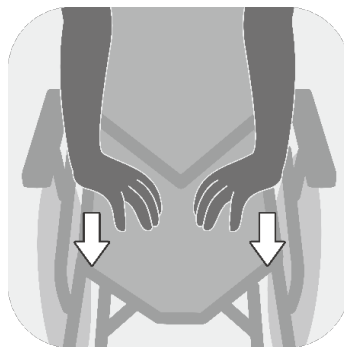

Figure 4.2



Figure 4.3



Figure 4.4



Figure 4.5



Figure 4.6

4.1.2 Folding

To fold your wheelchair, follow the steps below:

1. Remove the headrest frame. (See Figure 4.7 and refer to “4.1.3 Installing or removing the headrest” for details.)
2. Swivel the footplates outward up. (See Figure 4.8.)
3. Swing away the elevating legrest and pull up the legrest to remove. (See Figure 4.9.)
4. Pull up the knob ① on the rigidifying push bar (lateral support bar) , and then push down the rigidifying push bar (lateral support bar) ②. (See Figure 4.10.)
5. Pull up the seat upholstery by holding its central portion of the front and rear ends. (See Figure 4.11.)
6. Folding is now completed. (See Figure 4.12.)



Figure 4.7

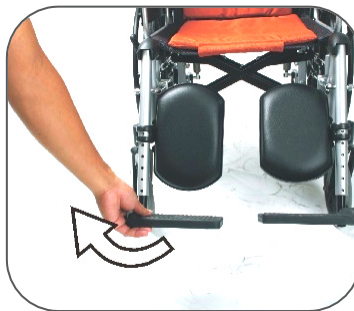

Figure 4.8



Figure 4.9



Figure 4.10

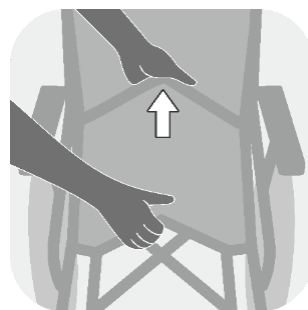

Figure 4.11



Figure 4.12

4.1.3 Installing or removing the headrest

1. To install the headrest, insert both tubes of the headrest frame into the backrest tubes (see Figure 4.13), until the release buttons on both sides pop out, so the headrest clicks into place.
2. To remove the headrest, just press the release buttons on both sides of the headrest frame tubes (see Figure 4.14), and then pull the headrest frame out of the backrest tubes.



Figure 4.13

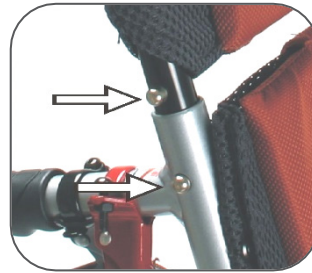

Figure 4.14



CAUTION

To avoid danger, mount the headrest properly. Make sure the headrest frame clicks into place before use.

4.1.4 Installing the elevating legrests

The elevating legrests are for those who need to elevate their legs or keep their legs at a certain angle for more comfort and support.

1. Turn the elevating legrest to the side, and attach the legrest onto the wheelchair. (See Figure 4.15 and 4.16.)
2. Swing the elevating legrest toward the inside of the wheelchair until it clicks into place. (See Figure 4.17.)
3. Repeat the steps above for the other legrest.



Figure 4.15



Figure 4.16



Figure 4.17

4.1.5 Removing the elevating legrests

1. To detach the elevating legrest, press the legrest lever. (See Figure 4.18.)
2. Swing the legrest to the side, and lift it up to release. (See Figure 4.19.)



Figure 4.18



Figure 4.19



WARNING

DO NOT attempt to lift the wheelchair by any removable (detachable) parts, such as the legrests. Lifting by means of any removable (detachable) parts of the wheelchair may result in injury to the user and/or assistant/attendant or damage to the wheelchair.

4.2 Making adjustments

4.2.1 Adjusting the headrest

1. Adjust the headrest frame to the most comfortable position. (See "[4.1.3 Installing or removing the headrest](#)" for details.)
2. Attach the 3D headrest pillow onto the headrest frame according to the Velcro.



4.2.2 Adjusting the recline angle



CAUTION

Before using the recline function, make sure of the following:

- The rigidifying push bar (lateral support bar) is mounted properly and its knob at the center is fully tightened.
- You have installed the anti-tippers properly to avoid tipping over.

1. Push the wheel lock levers forwards as far as possible on both sides of the wheelchair to engage the wheel locks. (See Figure 4.20.)
2. Place both hands on both sides of the rigidifying push bar (lateral support bar), and then squeeze the black recline lever on the right. (See Figure 4.21.)
3. Apply force to pull downwards with both hands at the same time while holding the recline lever firmly. Make the backrest recline slowly. When reaching the desired angle, release the recline lever to lock the backrest in place. (See Figure 4.22.)

The rigidifying push bar (lateral support bar) helps you recline the backrest in an easier way.



Figure 4.20



Figure 4.21



Figure 4.22

89°–161°



Seat to backrest angle (when recline function is activated)



CAUTION

- Do not use the recline function when the wheel locks are not engaged, the wheelchair is unoccupied, or the anti-tippers and headrest are not installed.
- When reclining, make sure the user's hands are placed in a safe and stable place to prevent them from falling and getting injured.
- The armrests and side guards must be installed. Removing them when using the recline function might cause danger.

4.2.3 Using the patented multi-functional armrests

4.2.3.1 Flipping back the armrests

Flipping back the armrests can help transfer the wheelchair user in an easier way.

1. First, park the wheelchair and push the wheel lock levers forwards as far as possible on both sides of the wheelchair to engage the wheel locks.
2. Pull up the armrest lever (see Figure 4.23), and then flip back the armrest (see Figure 4.24).
3. After transferring the user into or out of the wheelchair, you should put the armrests back into position. Just hold the armrest tube with your hand, and insert the armrest into the armrest base. (See Figure 4.25.)
4. Press down the armrest and make sure the lever and armrest base fully lock together. (See Figure 4.26.)

4.2.3.2 Removing the armrests

Removing the armrests can help transfer the wheelchair user in an easier way.

1. First, park the wheelchair and push the wheel lock levers forwards as far as possible on both sides of the wheelchair to engage the wheel locks.
2. Hold the armrest lever and armrest tube with your hand and lift the armrest up slightly. (See Figure 4.24.)
3. Pull the knob at the end of the armrest inward (see Figure 4.27), and then lift the entire armrest backwards to remove it (see Figure 4.28).



Figure 4.23



Figure 4.24



Figure 4.25



Figure 4.26



Figure 4.27



Figure 4.28

4.2.3.3 Mounting the armrests

Once the wheelchair user is transferred into or out of the wheelchair, you should put the armrest back into position.

1. First, park the wheelchair and push the wheel lock levers forwards as far as possible on both sides of the wheelchair to engage the wheel locks.
2. Align the hexagonal base at the end of the armrest with the armrest rotation bracket and insert it into the bracket (see Figure 4.29). Make sure the latch clicks into place.
3. Hold the armrest lever and the armrest tube with your hand, and then insert the armrest into the armrest base. (See Figure 4.25.)
4. Release the armrest lever and make sure the lever and armrest base fully lock together. (See Figure 4.26.)



Figure 4.29



Figure 4.30

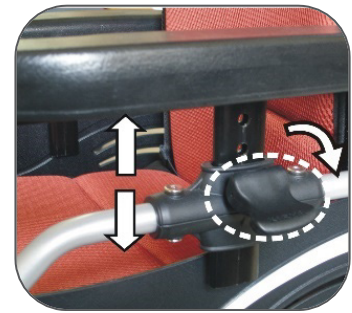

Figure 4.31

4.2.3.4 Adjusting the armrest height

1. Flip up the armrest height lever on the side of the armrest. (See Figure 4.30.)
2. Adjust the height of the armrest up or down according to the user's needs. (See Figure 4.31.)
3. Flip down the armrest height lever on the side of the armrest to lock the armrest back into place. (See Figure 4.31.)



CAUTION

When using the functions above, make sure the wheelchair is stationary and the wheel locks are engaged.

4.2.4 Using the elevating legrests

4.2.4.1 Using and adjusting the elevating legrests

1. You can elevate the legrest directly and stop anywhere you desired. (See Figure 4.32.)
2. Press the release lever to lower the legrest with one hand (see Figure 4.33), and maintain the stability of the legrest with the other hand.
3. To adjust footplate height, use the KARMA tool provided to loosen the bolt at the side of the legrest arm. Adjust to required height and re-tighten. (See Figure 4.34.)



Figure 4.32



Figure 4.33



Figure 4.34



CAUTION

When using the functions above, make sure the wheelchair is stationary and the wheel locks are engaged.

4.2.4.2 Adjusting the calf pads

The position of the calf pads can be adjusted horizontally or vertically according to the user's condition.

1. To adjust the calf pads, you can remove the elevating legrests from the wheelchair first. (Refer to "4.1.5 Removing the elevating legrests" for details.)
2. Put the elevating legrests on a level surface with the back of the calf pads facing towards you.
3. Use a 3 mm Allen key to loosen and remove the M5 bolts on the calf pads.
4. Adjust the calf pads to the desired position, and then re-tighten the M5 bolts using the 3 mm Allen key.



5. Re-install the elevating legrests onto the wheelchair. (Refer to "4.1.4 Installing the elevating legrests" for details.)

4.2.5 Adjusting the footplate height

1. To adjust the footplate height, use the KARMA tool provided to loosen the bolt at the side of the legrest arm.
2. Adjust it to the desired height, re-insert the bolt and make sure the footplate is firm. Then, tighten the nut as a locknut.
3. The footplate height must be at least 50 mm from the ground.



NOTE

- Make sure that the footplate height is adjusted properly according to the user's calf length to reduce pressure on the body.

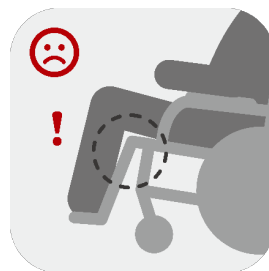

- The legrest height must be more than 50 mm.

4.2.6 Important DOs and DON'Ts

- Do keep axles clean and lubricate with light oil or maintenance spray.
- Don't try to detach the wheels while the wheelchair is occupied even it is installed with anti-tippers.

4.3 Transferring in and out

4.3.1 Transferring in

1. Engage both wheel locks.
2. Flip up the footplates.
3. The user lowers his or her body into the seat using the armrests for support.
4. Flip the footplates back down, so that the user can place his or her feet on them.
5. Release both wheel locks.



CAUTION

Always ensure that the front casters are in line with the rear wheels, the front caster forks are pointing forwards, and the back of the wheelchair is secure either against a wall or firmly held by an attendant.

4.3.2 Transferring out

1. Make sure that the wheelchair is near your final destination.
2. Move the wheelchair back sufficiently to ensure that the front casters are pointing forward, i.e. in line with the rear wheels and usually with the front caster forks pointing forward. Ensure that, where possible, the rear of the wheelchair is against a wall or, if not, it must be firmly held by an attendant.
3. Engage both wheel locks. The wheel lock levers must be pushed to lock.
4. Turn the footplates up and swing them to the side.
5. Slide forwards on the seat.
6. Place one foot firmly on the ground with the knee at a right angle and the other foot slightly apart and further back.
7. Place your hands on the front of the armrests and moving your weight forward, bring your head and shoulders up over your knees as you push yourself up.



CAUTION

- When transferring into and out of the wheelchair, make sure that the wheel locks are applied to prevent the wheelchair from sliding away. Also, ensure that the footplates are flipped up for ease of entering or exiting. (See Figure 4.23.)
- Never stand on the footplates when getting into or out of the wheelchair. (See Figure 4.24.)
- When getting into and out of the wheelchair, please use the wheel locks. The wheel locks levers are at the sides of the wheelchair.
- Please ensure that neither the tread on your tyres (tires) nor the brake block becomes too worn.
- Please ensure that the occupant's fingers do not get caught in the brake.



Figure 4.23



Figure 4.24

4.4 General use

4.4.1 Attendant pushing and self-propelled

- Do ensure that the wheel locks are always locked when the wheelchair is not being pushed. (See Figure 4.25.)
- Always make sure that both feet are safely on the footplates and that clothing is safely tucked out of the way and so cannot get caught in the wheels. (See Figure 4.26.)
- Always use both hands on the rigidifying push bar (lateral support bar) to control the wheelchair.



Figure 4.25



Figure 4.26

- Always avoid steep or uneven surfaces because the wheelchair may tip over. (See Figure 4.27.)
- Always avoid soft surfaces because the front casters may get bogged down. (See Figure 4.28.)



Figure 4.27



Figure 4.28

- Always be careful not to go too fast or turn too quickly and try to achieve a smooth steady ride.
- Before crossing railroad tracks, please stop completely and look both ways. Cross the tracks perpendicular to avoid your wheels getting stuck. Do not move at full speed over the railroad tracks.
- Be careful when going through a doorway that your hands and arms do not get injured.

PLEASE keep in contact with the person in the wheelchair. If you stop to look in shop windows or talk to people, remember to turn the wheelchair so that the person in the wheelchair does not have to turn.



WARNING

NEVER engage the wheel locks too quickly as this may tip the user out of the wheelchair.

4.4.2 Tilting by the attendant

1. Make sure both the user's feet are on the footplates and will not slip off. Make sure the handgrips are secure and cannot slip off.
2. Release both wheel locks.
3. Grasp the rigidifying push bar (lateral support bar) firmly.
4. Tell the person in the wheelchair that you are about to tilt the wheelchair backwards.
5. Put your foot against the end of the rear frame tube, and then pull back with both hands and push down and forwards with your hands. This will bring the wheelchair onto the rear wheels.



CAUTION

- When a wheelchair is tilted to about 25 degrees, it will balance on its rear wheels and be easy to hold. If it is tilted further back it will be difficult to hold and the person in the wheelchair will feel unsafe.
- Lower the wheelchair with your back straight, keep your foot against the relevant tipping lever at the back of the wheelchair, and lower the wheelchair slowly forwards softly to the ground.

4.4.3 Tilting by the user

1. Make sure your feet are on the footplates and will not slip off.
2. Release both wheel locks.
3. Grasp both handrims and give a firm, sudden forward push immediately before the obstacle, continue the momentum (be ready to keep pushing) until the obstacle is mounted.



CAUTION

- This method should only be attempted by people experienced in wheelchair use. Strong arms are also necessary. It is always better to have the help of an attendant.
- Leaning backwards causes the front caster to rise higher, BUT it is much safer to lean forwards and stay balanced.

4.4.4 Going down kerbs (curbs)



NOTE

It is always better to avoid kerbs (curbs) where possible by using ramped kerbs (curbs) or slopes and this operation is best attempted with the aid of an attendant.

4.4.4.1 Going down kerbs (curbs) forwards with an attendant



CAUTION

- This is the more difficult method and can jar the user but allows a better view of traffic.
- Be careful that the anti-tipper does not get caught on the kerb (curb) causing the user to fall.
- NEVER ALLOW THE WHEELCHAIR TO TIP FORWARDS WHEN GOING DOWN A KERB (CURB).

1. Position the wheelchair so that the front casters are near the edge of the kerb (curb) and make sure that the road is clear.
2. Move the wheelchair slowly and carefully forwards while tilting it back slightly. Be ready to take the weight when the rear wheels cross the kerb (curb) edge. Ensure that both rear wheels touch the ground at the same time to avoid tipping the wheelchair.
3. Gently lower the front casters. AVOID JARRING THE USER.

4.4.4.2 Going down kerbs (curbs) backwards with an attendant



CAUTION

This is the easier and smoother method, BUT it requires the attendant to step backwards into the road.

1. Back the wheelchair to the kerb (curb) edge and be careful that the rear wheels are equally near the edge.
2. Grasping the rigidifying push bar (lateral support bar), gently lower the rear wheels onto the road. Be prepared to control the weight as it descends, and ensure that the rear wheels touch ground at the same time.
3. Tilt the wheelchair back slightly and pull the tilted wheelchair far enough into the road so that the front casters and legrests can be lowered clear of the kerb (curb).

4.4.5 Going up kerbs (curbs)

NOTE

This operation is best attempted with the aid of an attendant and the best method is to go up kerbs (curbs) forwards as this maintains the direction of travel and is physically less demanding for the attendant.

4.4.5.1 Going up kerbs (curbs) forwards with an attendant

1. As the legrests nearly touch the kerb (curb), tilt the wheelchair. The wheelchair should be tilted just high enough to allow the front casters to roll smoothly onto the pavement.
2. Push the wheelchair forward until the rear wheels are touching the kerb (curb). Then, continuing the movement, lift at the rigidifying push bar (lateral support bar) while moving the wheelchair forwards.

4.4.5.2 Going up kerbs (curbs) backwards with an attendant

CAUTION

For safety's sake, we do not recommend using this method.

4.4.6 Going up or down steps/stairs

NOTE

Avoid flights of steps particularly if no extra help is available. Use ramps or lifts wherever possible.

1. Two attendants are necessary, each capable of carrying at least half of the combined weight of the person and the wheelchair.
2. Each helper should bend at the knees and grip the main frame: with the front attendant's hands just under the front of the seat, with the back attendant's hands holding the frame just under the rigidifying push bar (lateral support bar).

CAUTION

Never hold on to movable or detachable parts.

ALL LIFTING SHOULD BE DONE WITH A STRAIGHT BACK.

Straighten legs to lift the wheelchair. Carefully carry it up or down steps; be aware of how you place your feet -- do not cross them and trip yourself up.

4.5 Storing

Make sure the wheelchair is folded when stored.

NOTE

Please store the wheelchair in a location where it is out of direct sunlight, rain and dew. For more details, consult your KARMA dealer.

WARNING

Don't put anything on the wheelchair while it is in storage. Storing goods on a folded or unfolded wheelchair will cause damage and is not covered under warranty. (See the figure on the right.)



4.6 Transportation

The Ergo Recline series fulfills the performance requirements for a "Crash Test" of ISO 7176-19 (Report No. TSSM2302000051W0) and is suitable to use as a seat in vehicles that have been adapted for this purpose. The wheelchair must be securely restrained as described in this manual. The Ergo Recline series was tested with a four-point webbing system. For further information on the use of wheelchair restraints, please refer to the manufacturer's user guide.

KARMA always recommends that the user transfers to the vehicle seating, because using a wheelchair as a seat in a vehicle does not provide the equivalent level of safety of a vehicle seating system.

WARNING

Please transfer to a vehicle seat in the vehicle in all permitted cases.

4.6.1 Before use

1. Please detach all easily removable accessories from the wheelchair and store them in a safe place where they cannot move around and become a safety hazard.
2. A four-point tie-down system should tightly fasten the lower wheelchair frame to the transport vehicle. The Tie-Down Label (see the hook mark on the right) indicates the position of the fixing points for the tie-down restraints on the wheelchair. 
3. An occupant restraint system using both a pelvic belt and harness must also be fastened to the transport vehicle to ensure user safety. Again, please refer to the restraint system's instructions.
4. The attendant/transporter must double-check all fastening points for proper connection and tightness to assure the wheelchair user's safety. The attendant/transporter must fully understand the fastening system's usage and its weight limitations.
5. See <https://www.braunability.eu/en/products/tie-downs-and-seatbelts/wtors/> for more information.



CAUTION

- When transporting or lifting, never hold on to attachments or accessories (front/rear wheels, handrims, front casters, legrests, armrests, anti-tippers, etc.).
- All lifting should be done with a straight back. Straight legs to lift the wheelchair. Carefully carry it up or down steps; be aware of how you place your feet, do not cross them and trip yourself up.

4.6.2 Method of restraint

The Ergo Recline series was tested with four-point webbing systems. Please refer to the restraint manufacturer's user guide for further details of its operation.

4.6.3 Fitting the front restraints

1. Connect the straps around the wheelchair frame and front caster bracket as pictured below. The anchor point is marked with a yellow sticker .
2. Take the brakes off and reverse the wheelchair to tension the front straps. Apply wheelchair brakes (the brakes should be left on during transport).

4.6.4 Fitting the rear restraints

1. Attach rear straps into rail approximately 300 mm behind the wheelchair backrest.
2. Attach the hooks to the rear frame of the wheelchair as pictured below. The anchor point is marked with a yellow sticker . Tension the restraint until the wheelchair is secure.



Fitting the front restraints and rear restraints

4.6.5 Fitting seat belt

1. Fasten the three-point safety belt around the user.
2. The occupied wheelchair should be located in a forward-facing configuration, with the wheel locks applied.
3. Pelvic restraints should make full contact across the front of the body near the junction of the thigh and pelvis as pictured below (correct seat belt position).

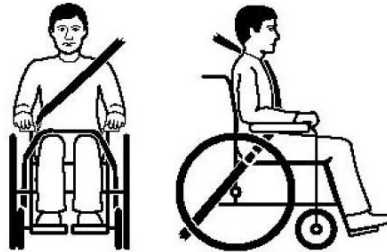

Correct seat belt position

4. Restraints should not be held away from body by wheelchair components such as armrest or wheels as pictured below (incorrect seat belt position).



Incorrect seat belt position

4.7 Pelvic belt

4.7.1 How to assemble and disassemble a pelvic belt

1. Loosen the fourth and fifth screws of both side of seat upholstery and insert the pelvic belt in between the fourth and fifth screw holes. (See Figure 4.29.)
2. Keep the pelvic belt in 45 degrees for comfortable usage. (See Figure 4.30.)
3. Put the seat upholstery back and tighten the screws.

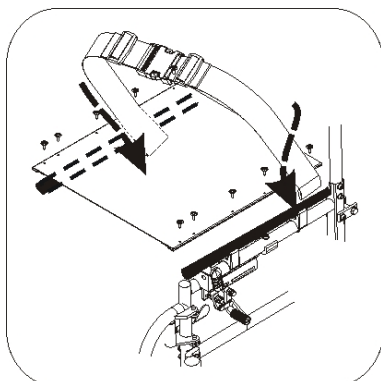

Figure 4.29

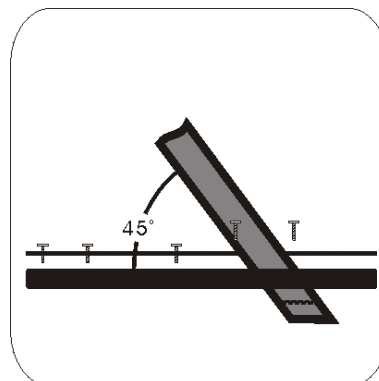

Figure 4.30

4.7.2 Adjusting the length of a pelvic belt

1. Identify the required length of the pelvic belt. (See Figure 4.31.)
2. Push the two part of belt through buckle to make the belt longer or shorter. (See Figure 4.32.)
3. Pull the two part of belt tight. (See Figure 4.33.)
4. Push buckle up to the plastic clip so that the belt cannot slip out of position. Please check that there is no gap between the clip and buckle.



WARNING

We recommend that the pelvic belt is fitted quite tightly around the pelvis. Please tighten until you can just get your fingers between the user and the pelvic belt. Please check that the pelvic belt is fastened correctly as recommended. If this is not possible, please consult your supplier.



Figure 4.31



Figure 4.32



Figure 4.33

4.7.3 How to operate a pelvic belt

1. When you sit on the wheelchair, fasten the pelvic belt.
2. Adjust the pelvic belt and make it fit your body for comfort and security.
3. When you don't use it, please fasten the pelvic belt to avoid the belt dropping into rear wheels during motion.

4.7.4 Maintenance

The pelvic belt is made from 100% polyester fiber and the clasp is made from plastic. It does not require any maintenance but should be inspected every month to ensure that the edges are not frayed and weekly to make sure that it correctly fits the user. If there are any signs of deterioration, please replace it immediately.

5. Inspection and maintenance

5.1 Daily check

Check the following items before traveling. If you find anything abnormal, visit your KARMA wheelchair dealer for further inspection before using it.

- Examine wheel locks/attendant brakes, checking for wear, damage and misalignment. Replacing or adjusting the wheel locks/attendant brakes should be carried out by your approved repairer.
- Check that the handgrips are not damaged and are securely bonded to the rigidifying push bar (lateral support bar).
- Check anti-tippers are not damaged and are securely attached.
- Check that the anti-tippers' wheels and frame are not damaged and are securely mounted.
- Before using the wheelchair, make sure all nuts and bolts are tight. Check all parts for damage or wear and have a qualified technician replace it if necessary. Check all parts for proper adjustment. Inspect wheel locks/attendant brakes for proper operation.
- The wheels and tyres (tire) should be checked periodically for cracks and wear, and should be replaced by a qualified technician.
- A qualified technician can be found at an authorized distributor/dealer.



CAUTION

Visit a KARMA wheelchair dealer for inspection and maintenance if you find anything abnormal.

5.2 Regular maintenance record

In order to ensure that your wheelchair is in good condition, please contact KARMA authorized dealers regularly and make further wheelchair inspection and maintenance records. We recommend that you inspect and maintain your wheelchair **every 6 months**.

A maintenance/service fee may apply.



WARNING

Even if you don't use the vehicle for a long time, the wheelchair should still be maintained regularly. You should clean your wheelchair regularly.

Item	Weekly	Monthly
GENERAL		
● Wheelchair rolls straight (no excessive drag or pull to one side)		V
FRAME AND CROSSBARS		
● Inspect frame structure for small cracks/fissures		V
● Inspect for bent frame or crossbars		V
WHEEL LOCKS/ATTENDANT BRAKES		
● Do not interfere with tyres (tires) when rolling		V
● Pivot points free of wear and looseness		V
● Easy to engage	V	
● Prevent wheelchair from moving when engaged	V	
SEAT & BACKREST		
● Inspect for rips or sagging	V	
● Inspect for loose or broken hardware		V
FRONT CASTERS		
● Inspect the front casters for smooth rotation of the caster wheel and caster assembly		V
● Inspect the front caster for wear in the bearings/mountings and for tyre (tire) wear or damage		V
REAR WHEELS		
● Quick-release axles lock properly; lubricate if necessary	V	
● No excessive side movement or binding when lifted and spun		V
● Inspect for cracked, bent or broken spokes	V	
ARMRESTS		
● Inspect the detachable armrest button for effective locking		V
● Make sure the armrest detaches and flips back properly		V
LEGRESTS		
● Inspect the footplate height adjustment screws are securely tightened		V
● Inspect the legrest release lever for effective locking		V

Item	Weekly	Monthly
TYRES (Tires)		
<ul style="list-style-type: none"> ● Inspect for flat spots, cracks and wear ● Check tyre (tire) tread depth is more than 1 mm ● If pneumatic tyres (tires), check for proper inflation; tyre (tire) pressures are located on the side of the tyre (tire) 	 V V	 V



CAUTION

- If you find anything abnormal, stop using the wheelchair immediately and visit a KARMA wheelchair dealer for inspection and maintenance.
- As with any wheelchair, the wheels and tyres (tires) should be checked periodically for cracks and wear, and should be replaced. Failure to keep tyres (tires) at the correct pressure will reduce the braking efficiency.
- Never disassemble or modify the wheelchair frame structure. Otherwise, injury or damage may occur. This will void the warranty.

6. Options and accessories

- Chest strap
Used to fasten across the chest, providing added support and stability.

7. Troubleshooting

7.1 Common issues and troubleshooting tips

You can inspect the following before taking your wheelchair to a KARMA wheelchair dealer.

Issue	Checking Points and Corrective Action
1. Wheelchair Veers Right/Left	<ul style="list-style-type: none">● Check the tyres (tires) for correct and equal pressure● Check the front caster bracket angle● Check that the rear wheels are equally spaced from the seat frame
2. Sluggish Turn or Performance	<ul style="list-style-type: none">● Check the tyres (tires) for correct and equal pressure● Check for loose nuts and bolts
3. Front caster Flutter/Wobble	<ul style="list-style-type: none">● Check the tyres (tires) for correct and equal pressure● Check for loose nuts and bolts● Check the front caster bracket angle
4. Squeaks and Rattles	<ul style="list-style-type: none">● Check for loose nuts and bolts
5. Looseness in Wheelchair	<ul style="list-style-type: none">● Check for loose nuts and bolts

If you cannot solve the problem by yourself, contact your KARMA wheelchair dealer for help.

8. Specifications

Product Model	Ergo Recline (KM-5001)			
Nominal seat width (mm/in) ¹	415	465	415	465
Nominal seat depth (mm/in) ²	420	420	420	420
Front caster/Rear wheel size (in)	8 x 14		8 x 20	
Backrest height (mm)	495	495	495	495
Headrest height above seat (mm)	725–865	725–865	725–865	725–865
Armrest to seat distance (mm)	220–300	220–300	220–300	220–300
Front location of armrest structure (mm)	330	330	330	330
Seat surface height at front edge (mm)	500	500	500	500
Footrest to seat distance (mm)	365–440	365–440	365–440	365–440
Effective seat width (mm)	480	530	480	530
Effective seat depth (mm)	430	430	430	430
Seat plane angle (X°)	9	9	9	9
Backrest angle (X°)	8–80	8–80	8–80	8–80
Seat to backrest angle (X°)	89–161	89–161	89–161	89–161
Leg to seat angle (X°)	115–192	115–192	115–192	115–192
Overall length with legrest (mm)	1190–1815	1190–1815	1190–1815	1190–1815
Overall width (mm)	590	640	640	690
Overall height (mm)	700–1300	700–1300	700–1300	700–1300
Folded length (mm)	790	790	850	850
Folded width (mm)	340	340	400	400
Folded height (mm)	940	940	940	940
Total mass (kg)	21.1	21.2	21.8	21.9
Mass of the heaviest part (kg)	13.3	13.4	14.2	14.3
Maximum user weight (kg)	115		115	

Product Model	Ergo Recline (KM-5001)			
Minimum turning radius (mm)	935	945	905	915
Minimum turning radius without user (mm)	880	890	850	860
Pivot width (mm)	1290	1300	1310	1320
Static stability downhill (X°)	18		18	
Static stability uphill (X°)	N/A		N/A	
Static stability uphill with anti-tippers (X°)	22		22	
Static stability sideways (X°)	11		11	
Handrim diameter (mm)	N/A	N/A	430	430
Horizontal location of axle (mm)	110	110	75	75

1. **Nominal seat width** is measured the width of seat cushion at 120 mm in front of the backrest. This value is mainly used in the product ordering process.
 2. **Nominal seat depth** is measured from the front end of the seat cushion to the back cushion. This value is mainly used in the product ordering process.
- This wheelchair conforms to the requirements and test methods for static, impact and fatigue strengths (ISO 7176-8).
 - The actual product specifications differ from the data in the table by ± 10 mm ± 0.5 kg.
 - The actual product specifications may vary according to different configurations.
 - KARMA reserves the right to modify information herein without further notice.
 - Please scan the **QR code** to watch more instructions of the measurement methods on the KARMA website.



9. Cleaning and recycling

9.1 Cleaning

In order to lengthen the life of your wheelchair, it is suggested that you clean the wheelchair periodically (if not daily), especially after it is used in the rain or snow. We suggest that you don't use your wheelchair in the rain or snow. If you are traveling and get caught in the rain, we suggest you try to find shelter while waiting it out. If you can't find shelter, proceed to your destination.

9.1.1 Frame

Wipe the frame with a damp cloth.

9.1.2 Upholstery

- When cleaning the upholstery, use warm water and a mild soap.
- Upholstery cleaner/foam can also be used, but avoid other cleaning solvents.

9.2 Post-consumer recycling

A post-consumer recycling plan should follow the Environmental Protection Administration's regulations. The items listed below are for reference only as local laws and regulations may vary.

Material	Part Name	Method
Aluminum-alloy	Frame	Recyclable
Plastic	Modular Components	Recyclable
Paper	User Manual	Recyclable

- There are many organizations in many countries/regions you can find on the Internet that will accept used goods for charity. Please search the Internet to help less fortunate individuals and protect our planet for future generations. If you do not have access to the world wide web please use your local phone directory, ask for operator assistance or go to your local government center for more information. Earth Day is every day.
- Check with your local recycling center on where and how to recycle your wheelchair as this information varies from region to region.

10. Warranty

10.1 Serial number

To ensure after-sales service and warranty, please record and fill in the serial number which can be found on the frame.

This warranty is VOID if the original wheelchair serial number is removed or altered.

Model	
Serial Number	

10.2 Warranty policy

10.2.1 Contents and Duration of Warranty

- If the parts of the product need to be repaired or replaced due to manufacturing defects, they can be repaired or replaced free of charge within the warranty period (a repair of this kind will hereafter be called warranty maintenance).
- Frame and cross-braces are warranted for a period of 5 years and gas strut for a period of 1 year after delivery to the customer, then the affected parts will be repaired or replaced free of charge.
- Consumable parts such as brakes, bearings, footplates, pads, side guards, upholsteries, wheels and similar parts are excluded from the warranty.
- Warranty maintenance can be performed by authorized KARMA wheelchair dealers only.
- KARMA is not responsible for the transportation costs for repair and replacement.
- Warranty maintenance is the repair or replacement according to the condition of the parts, and replaced parts will be the property of KARMA.
- KARMA reserves the right to modify product specifications without further notice; KARMA is not responsible for any changes to product specifications.

10.2.2 The Claims from This Warranty Shall Not Arise for The Following Reasons

- The product or part has been damaged by accident, improper use, incorrect assembly or poor maintenance. The evaluation of it is the privilege of KARMA.
- Damage resulting from normal wear and tear.
- Any overloading of the product, please check the label for maximum user weight.
- The product or part has not been maintained or serviced in accordance with the manufacturer's recommendations as shown in the User Manuals and/or the Service Manuals.
- Use or install parts or accessories which are not manufactured or not approved by KARMA.
- Damage resulting from use in unsuitable environments.
- Damage resulting from any addition, modification, or alteration of the product or

parts without the approval by KARMA.

- Damage resulting from external factors, such as chemicals, oil, debris, etc.
- Damage caused by natural disasters.

10.2.3 KARMA is Not Responsible for The Following Costs

- Replacement or refill of consumable parts, oil or lubricant.
- Product inspection, adjustment, lubrication, cleaning, etc.
- The costs of regular inspection and maintenance of product.
- The product is not repaired by the authorized dealer designated by KARMA.

10.2.4 Responsibilities

The Responsibilities of the User

- Fully adhere to operation guidelines set forth in this manual.
- Perform self-inspection and basic maintenance.
- Keep a record of self-inspections and basic maintenance.
- Not permit any alteration, addition, or modification or use of parts not manufactured by KARMA.
- Thoroughly read and understand this manual.

The Responsibilities of the Dealer

- Follow this manual and educate users about product operation and basic maintenance.
- Verify and check whether the warranty conditions are met.
- Provide relevant warranty information and recommendations for improvements.

10.2.5 Transfer of Warranty Rights

If you purchase a second-hand KARMA wheelchair while it is still within the warranty period, bring this manual and the wheelchair to the authorized dealer and perform necessary product inspection, maintenance and warranty inheritance procedure.

Full Name:	
Gender:	
Date of Birth:	
Address:	
Model:	
Serial Number:	
Date of Purchase:	

Dealer's Data

Name of the Store:	
Phone No. and Address:	

If you have any suggestions for how to improve our products, please don't hesitate to contact your local dealer, and let us know what you think of your wheelchair. Thank you and enjoy!

karma

A Better Wheelchair, A Better Fit



KARMA MOBILITY S.L European Support Center
www.karmamobility.es
+34 984 390 907
karma@karmamobility.es

KARMA MOBILITY LTD. UK representative
www.karmamobility.co.uk
+44 845 630 3436
info@karmamobility.co.uk

KARMA MEDICAL PRODUCTS CO., LTD.
www.KarmaMedical.com
+886 5 206 6688
globalsales@karma.com.tw